

## Medium Pressure Filter

### Pi 360

Operating pressure 210 (315) bar, Nominal size up to 300

#### 1. Features

##### Efficient filters for modern hydraulic systems

- Modular design
- Minimal pressure loss
- Compact design
- Visual / electrical / electronic differential pressure indication
- Threaded ports

##### Quality filters, easy to service

- Highly efficient Sm-x filter elements
- $\beta$ -rated elements per ISO 4572
- Large dirt holding capacity and high differential pressure stability providing optimum element service life
- 100% bubble-point tested elements

##### Worldwide sales



## 2. Flow rate/pressure drop curve compl. filter

■ 190 mm<sup>2</sup>/s (25° E)  
■ 33 mm<sup>2</sup>/s (4,5° E)

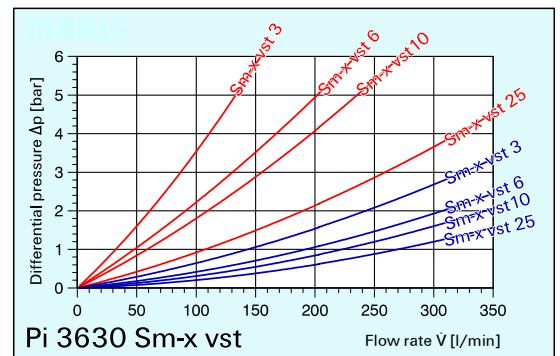
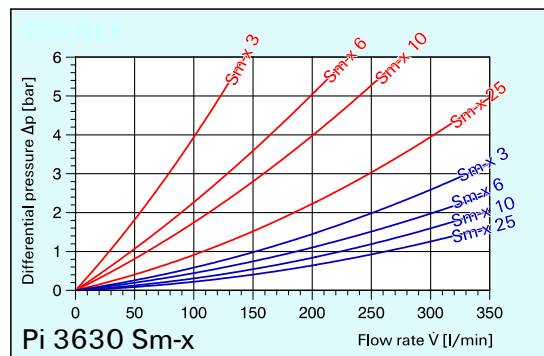
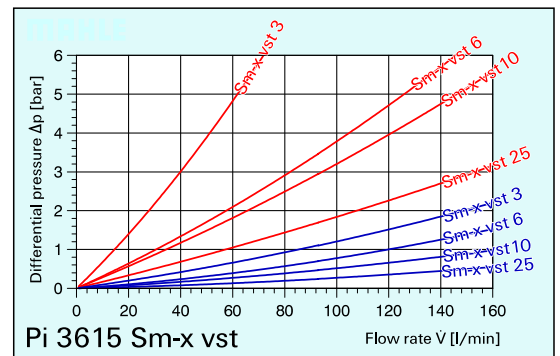
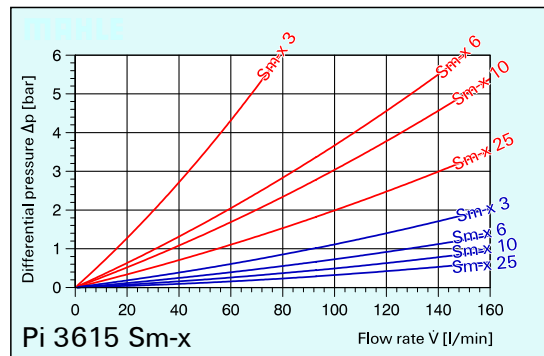
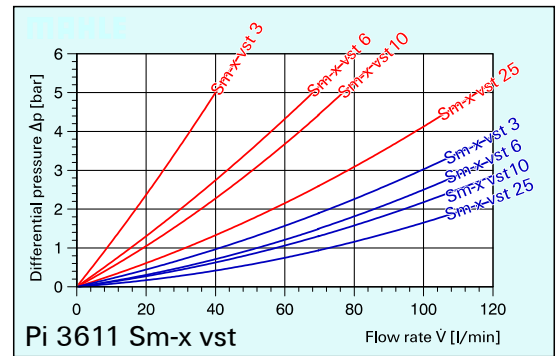
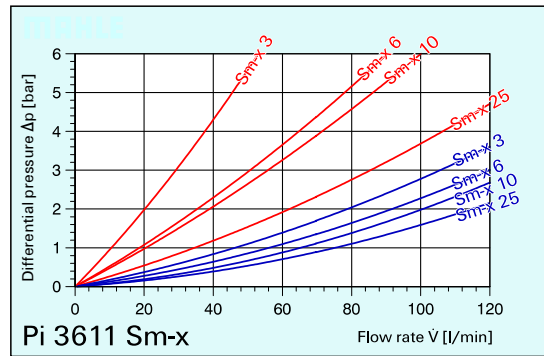
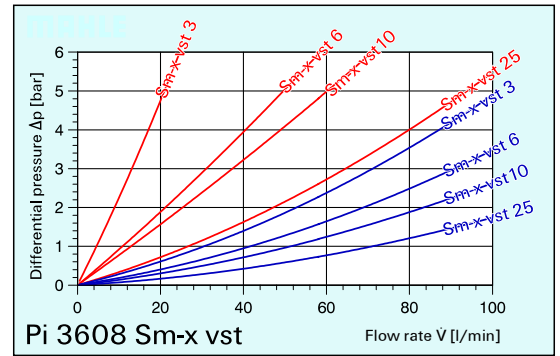
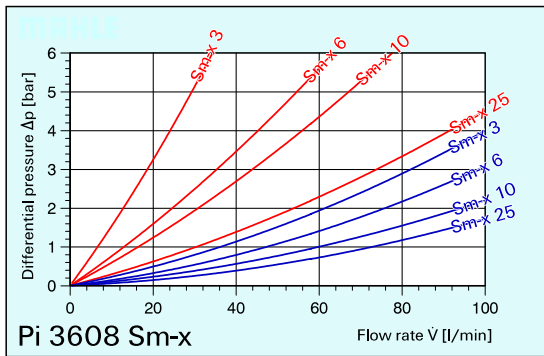
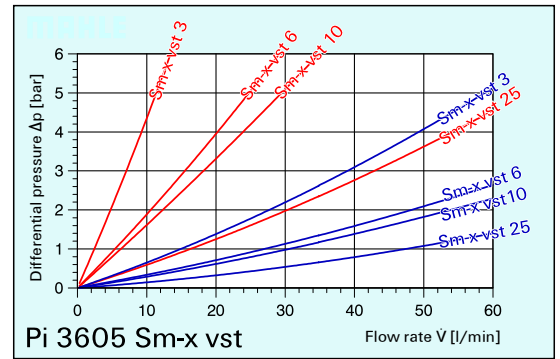
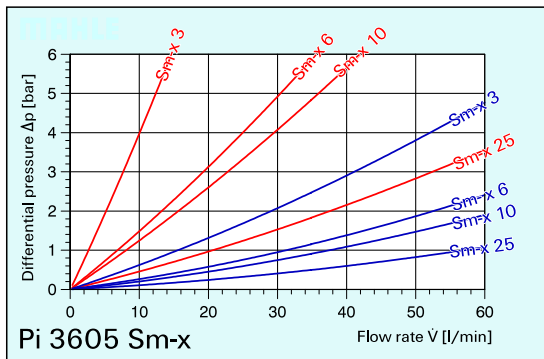

### 3. Separation characteristics

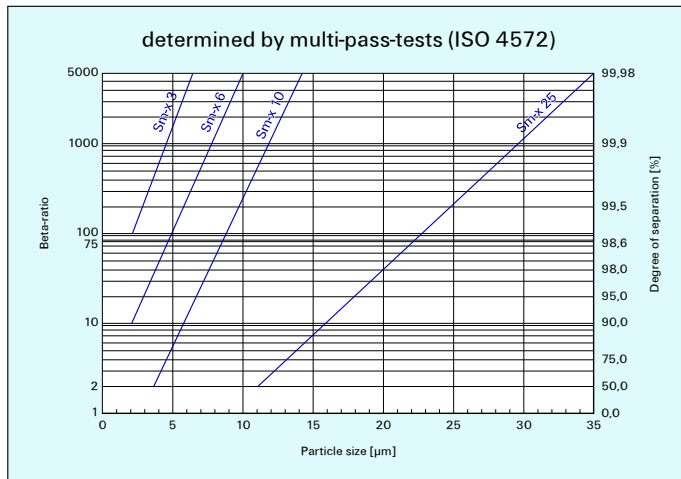

### 4. Filter performance data

tested according to ISO 4572 (multi-pass-test)

Sm-x-elements  
with  $\Delta p$  20 bar

Sm-x 3  $\beta_3 \geq 75$   
 Sm-x 6  $\beta_6 \geq 75$   
 Sm-x 10  $\beta_{10} \geq 75$   
 Sm-x 25  $\beta_{25} \geq 75$

Sm-x-vst-elements  
with  $\Delta p$  210 bar

Sm-x vst 3  $\beta_3 \geq 75$   
 Sm-x vst 6  $\beta_6 \geq 75$   
 Sm-x vst 10  $\beta_{10} \geq 75$   
 Sm-x vst 25  $\beta_{25} \geq 75$

at 7 bar differential pressure

at 16 bar differential pressure

#### Example for ordering filters:

1. Housing design  $\dot{V} = 80$  l/min,  
electrical indication

Type-no. Pi 3608-15

Order-no. 766.628.2

+ 2. Filter element Sm-x vst 3

Type-no. Pi 2208

Order-no. 768.020.0

### 7. Order numbers

#### 7.1 Housing design

Part number	Type number	Nominal size NG	① Standard *	② With bypass valve and indicator cavity	③ With bypass valve and visual indicator	④ With bypass valve and visual/electrical indicator	⑤ With visual indicator	⑥ With visual/electrical indicator
765.599.6	Pi 3605-60	<b>50</b>						
766.621.7	Pi 3605-11							
766.622.5	Pi 3605-12							
765.604.4	Pi 3605-13							
766.623.3	Pi 3605-14							
766.624.1	Pi 3605-15							
765.600.2	Pi 3608-60	<b>80</b>						
766.625.8	Pi 3608-11							
766.626.6	Pi 3608-12							
765.603.6	Pi 3608-13							
766.627.4	Pi 3608-14							
766.628.2	Pi 3608-15							
765.601.0	Pi 3611-60	<b>110</b>						
766.629.0	Pi 3611-11							
766.630.8	Pi 3611-12							
765.602.8	Pi 3611-13							
773.182.1	Pi 3611-14							
766.631.6	Pi 3611-15							
764.784.5	Pi 3615-60	<b>150</b>						
773.185.4	Pi 3615-11							
766.632.4	Pi 3615-12							
765.598.8	Pi 3615-13							
773.186.2	Pi 3615-14							
773.184.7	Pi 3615-15							
765.597.0	Pi 3630-60	<b>300</b>						
773.189.6	Pi 3630-11							
766.633.2	Pi 3630-12							
764.783.7	Pi 3630-13							
773.190.4	Pi 3630-14							
773.188.8	Pi 3630-15							

\*When using standard filter (without options) collapse pressure of the element may not be exceeded.

## 5. Test regulations

MAHLE filter elements are manufactured respectively, tested in accordance with the following international standards:

Norm	Designation
ISO 2941	Hydraulic-fluid power-Filter elements-Verification of collapse / burst resistance
ISO 2942	Hydraulic-fluid power-Filter elements-Verification of fabrication integrity and determination of the first bubble point
ISO 2943	Hydraulic-fluid power-Filter elements-Verification of material compatibility with fluids
ISO 3723	Hydraulic fluid power-Filter elements-Method for end load test
ISO 3724	Hydraulic fluid power-Filter elements-Verification of flow fatigue characteristics
ISO 3968	Hydraulic fluid power-Filters-Evaluation of pressure drop versus flow characteristics
ISO 10 771.1	Fatigue pressure testing of metal containig envelopes in hydraulic fluid applications.
ISO 16 889	Hydraulic Fluidpower filters-Multi-pass method for evaluation filtration performance of a filterelement

## 6. Symbols

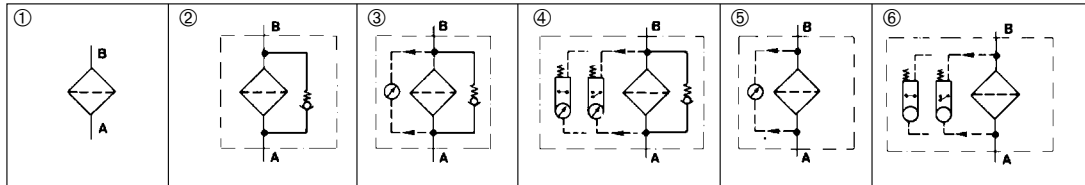

## 7.2 Filter elements\* ( ) = filter surface area [ ] = type number

inorganic paper								
	Sm-x 3 Δp 20 bar	Sm-x 6 Δp 20 bar	Sm-x 10 Δp 20 bar	Sm-x 25 Δp 20 bar	Sm-x vst 3 Δp 210 bar	Sm-x vst 6 Δp 210 bar	Sm-x vst 10 Δp 210 bar	Sm-x vst 25 Δp 210 bar
	( 590 cm <sup>2</sup> )	( 590 cm <sup>2</sup> )	( 590 cm <sup>2</sup> )	( 590 cm <sup>2</sup> )	( 470 cm <sup>2</sup> )	( 470 cm <sup>2</sup> )	( 470 cm <sup>2</sup> )	( 470 cm <sup>2</sup> )
					768.019.2	794.353.3	768.038.2	768.050.7
	768.013.5	794.350.9	768.032.5	768.044.0				
	768.013.5	794.350.9	768.032.5	768.044.0	[Pi 2205]	[Pi 5205]	[Pi 3205]	[Pi 4205]
	768.013.5	794.350.9	768.032.5	768.044.0				
	[Pi 2105]	[Pi 5105]	[Pi 3105]	[Pi 4105]	768.019.2	794.353.3	768.038.2	768.050.7
					768.019.2	794.353.3	768.038.2	768.050.7
	( 1150 cm <sup>2</sup> )	( 1150 cm <sup>2</sup> )	( 1150 cm <sup>2</sup> )	( 1150 cm <sup>2</sup> )	( 900 cm <sup>2</sup> )	( 900 cm <sup>2</sup> )	( 900 cm <sup>2</sup> )	( 900 cm <sup>2</sup> )
					768.020.0	794.354.1	768.119.0	768.051.5
	768.014.3	794.351.7	768.034.1	768.045.7				
	768.014.3	794.351.7	768.034.1	768.045.7	[Pi 2208]	[Pi 5208]	[Pi 3208]	[Pi 4208]
	768.014.3	794.351.7	768.034.1	768.045.7				
	[Pi 2108]	[Pi 5108]	[Pi 3108]	[Pi 4108]	768.020.0	794.353.3	768.119.0	768.051.5
					768.020.0	794.353.3	768.119.0	768.051.5
	( 1700 cm <sup>2</sup> )	( 1700 cm <sup>2</sup> )	( 1700 cm <sup>2</sup> )	( 1700 cm <sup>2</sup> )	( 1315 cm <sup>2</sup> )	( 1315 cm <sup>2</sup> )	( 1315 cm <sup>2</sup> )	( 1315 cm <sup>2</sup> )
					768.021.8	794.355.8	768.039.0	768.052.3
	768.015.0	794.352.5	768.033.3	768.046.5				
	768.015.0	794.352.5	768.033.3	768.046.5	[Pi 2211]	[Pi 5211]	[Pi 3211]	[Pi 4211]
	768.015.0	794.352.5	768.033.3	768.046.5				
	[Pi 2111]	[Pi 5111]	[Pi 3111]	[Pi 4111]	768.021.8	794.355.8	768.039.0	768.052.3
					768.021.8	794.355.8	768.039.0	768.052.3
	( 2350 cm <sup>2</sup> )	( 2350 cm <sup>2</sup> )	( 2350 cm <sup>2</sup> )	( 2350 cm <sup>2</sup> )	( 2010 cm <sup>2</sup> )	( 2010 cm <sup>2</sup> )	( 2010 cm <sup>2</sup> )	( 2010 cm <sup>2</sup> )
					768.022.6	795.512.3	768.040.8	768.053.1
	768.016.8	795.509.9	768.035.8	768.047.3				
	768.016.8	795.509.9	768.035.8	768.047.3	[Pi 2215]	[Pi 5215]	[Pi 3215]	[Pi 4215]
	768.016.8	795.509.9	768.035.8	768.047.3				
	[Pi 2115]	[Pi 5115]	[Pi 3115]	[Pi 4115]	768.022.6	795.512.3	768.040.8	768.053.1
					768.022.6	795.512.3	768.040.8	768.053.1
	( 4420 cm <sup>2</sup> )	( 4420 cm <sup>2</sup> )	( 4420 cm <sup>2</sup> )	( 4420 cm <sup>2</sup> )	( 3800 cm <sup>2</sup> )	( 3800 cm <sup>2</sup> )	( 3800 cm <sup>2</sup> )	( 3800 cm <sup>2</sup> )
					768.023.4	795.513.1	768.041.6	768.054.9
	768.017.6	795.510.7	768.036.6	768.048.1				
	768.017.6	795.510.7	768.036.6	768.048.1	[Pi 2230]	[Pi 5230]	[Pi 3230]	[Pi 4230]
	768.017.6	795.510.7	768.036.6	768.048.1				
	[Pi 2130]	[Pi 5130]	[Pi 3130]	[Pi 4130]	768.023.4	795.513.1	768.041.6	768.054.9
					768.023.4	795.513.1	768.041.6	768.054.9

\*further elements upon request

## 8. Specifications

Design:	line mounting filter
Operating pressure:	210 bar*
Static test pressure:	275 bar*
Temperature range:	-10 °C to +120 °C (other temperature ranges on request)
Bypass opening pressure:	$\Delta p$ 7 bar $\pm$ 10 %
Filter head material:	GGG
Filter bowl material:	St
Material of seals:	NBR / PTFE / Cu
Activating pressure of visual / electrical differential pressure indicator:	$\Delta p$ 5 bar $\pm$ 10 %
Electrical data of contamination indicator:	
Maximum voltage:	230 V $\sim$ / =
Maximum current on contact:	2,5 A
Maximum contact load:	60 VA / 40 W
Inrush current:	70 VA
Type of protection:	IP 65 when inserted and secured
Contact:	bistable
Cable connection:	PG 11 $\varnothing$ 6-10

The electrical indicator function can be changed from the Normally Open position to the Normally Closed position or visa versa by inverting the electrical section.

With the inrush current of 70 VA the indicator can trigger small contactors or contactor relays.

Inductivity in the direct current may require the use of a signal eraser.

For further information and executions please see our leaflet "contamination indicators".

Filters compatible with standard mineral oils.

Please contact us in case of using other media.

\* Types Pi 3605, Pi 3608 and Pi 3611 have an operating pressure of 315 bar/test pressure 410 bar.

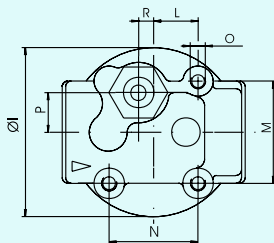

Pi 3605 - Pi 3611

Pos 1 - Visual contamination indicator

Pos 2 - El. upper section connector according DIN 43650  
Execution: Pis 3092, 3105, 3115

Pos 3 - El. upper section connector according DIN 43651  
Execution: Pis 3102, 3122, 3110, 3132

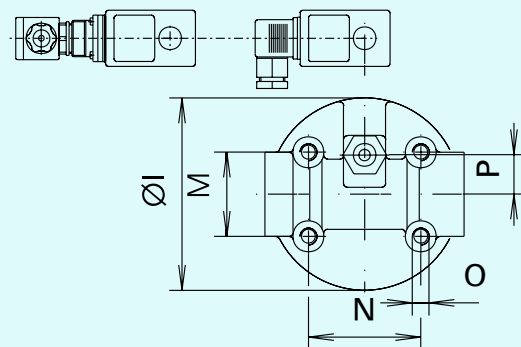
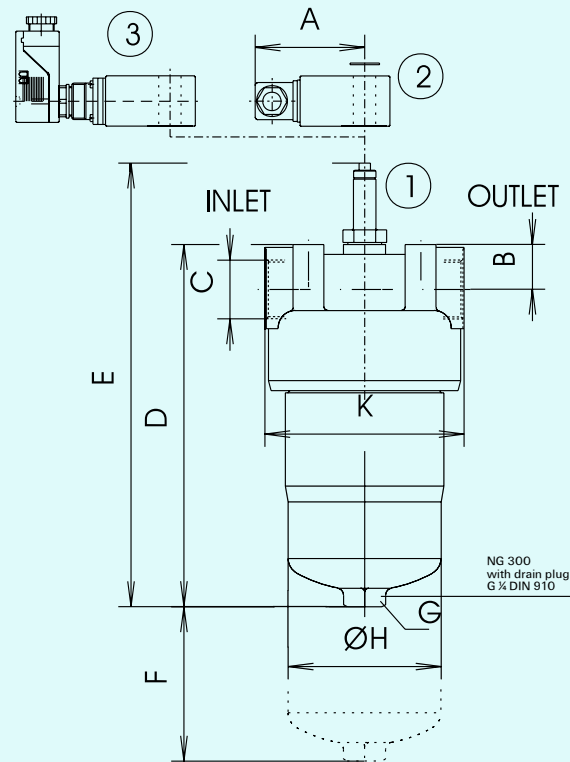

Pi 3615, Pi 3630

## 9. Dimensions

All dimensions (except "C") in mm

Dimension Type	Dimension																Weight [kg]
	A	B	C	D	E	F	G (SW)	H	I	K	L	M	N	O	P	R	
Pi 3605	78	31	G ½	189	247	80	27	66	90	92	23,5	54	47	M8x16	21	8	4,1
Pi 3608	78	31	G ¾	267	325	80	27	66	90	92	23,5	54	47	M8x16	21	8	5
Pi 3611	78	31	G ¾	343	401	80	27	66	90	92	23,5	54	47	M8x16	21	8	5,9
Pi 3615	78	32	G 1 ¼	259	315	110	30	109	137	142	-	60	80	M 12x16	28	-	9,8
Pi 3630	78	32	G 1 ¼	384	440	110	30	109	137	142	-	60	80	M 12x16	28	-	12,5

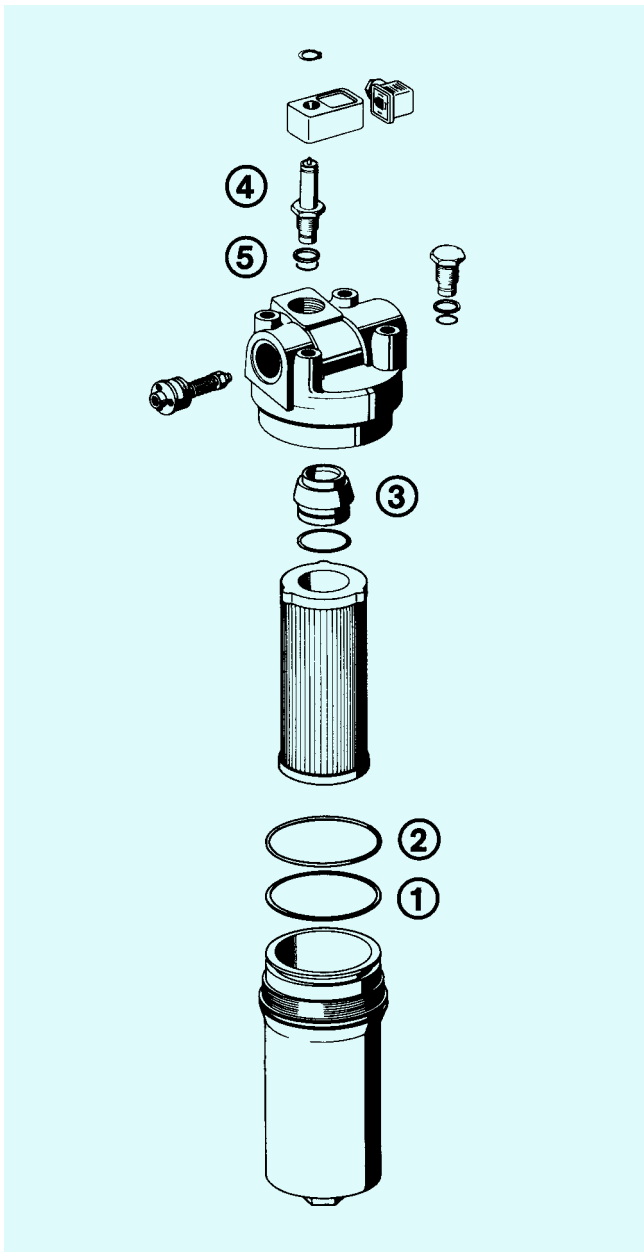

## 10. Installation, operating and maintenance instructions

### 10.1 Filter installation

When installing the filter make sure that sufficient space is available to remove filter element and filter bowl.

Preferable the filter should be installed with the filter bowl pointing downwards.

The contamination indicator must be visible.

### 10.2 Connecting the electrical contamination indicator

The electrical indicator is connected via a 2-pole appliance plug according DIN 43650 with poles marked 1 and 2.

The electrical section can be inverted to change from Normally Open position to Normally Closed position or vice versa.

### 10.3 When must the filter element be replaced?

- Filters equipped with visual and electrical contamination indicator:  
During cold starts, the indicator may give a warning signal. Depress the red button of the visual indicator once again only after operating temperature has been reached. If the red button immediately pops out again and/or the electrical signal has not switched off after reaching operating temperature, the filter element must be replaced after the end of the shift.
- Filters without contamination indicator: the filter element should be replaced after the trial run or flushing of the system. Afterwards follow instructions of the manufacturer.
- Please always ensure that you have original MAHLE replacement elements in stock: disposable elements (Sm-x) cannot be cleaned.

### 10.4 Element replacement

- Stop system and relieve filter from pressure.
- Unscrew the filter bowl by turning counter-clockwise. Clean the bowl using a suitable cleaning solvent.
- Remove filter element with a side-to-side motion.
- Check O-ring and back-up ring on the filter bowl for damage. Replace, if necessary.
- Make sure that the part number on the spare element corresponds with the part number of the filter label. Open the plastic bag and push element over the spigot in the filter head. Now remove plastic bag.
- Complete installation by screwing on the bowl, turning clockwise until it comes to a full stop. Back off the bowl  $\frac{1}{8}$  turn.

## 11. Spare parts list

Pos.	Part no./housing	
	Pi 3605–Pi 3611	Pi 3615–Pi 3630
①	Seal kit	Seal kit
–	NBR 763.715.0	NBR 763.718.4
–	FPM 763.716.8	FPM 763.719.2
③	EPDM 763.717.6	EPDM 763.720.0
④	Contamination indicator	
	visual	visual/electrical
	766.991.4	766.986.4
	Pis 3093/5 bar	Pis 3092/5 bar
	electrical upper part only	753.655.0
⑤	Seal kit for contamination indicator	
	NBR	776.027.5
	FPM	776.028.3
	EPDM	776.029.1

Subject to technical alteration without prior notice.

# MAHLE

MAHLE Filtersysteme GmbH

Bereich Industriefilter · Schleifbachweg 45 · D-74613 Öhringen · Postfach 13 09 · D-74603 Öhringen  
 Telefon (0 79 41) 67-0 · Telefax (0 79 41) 67-429 · Internet: <http://www.mahle.com> · E-mail: [ub2.industrie@mahle.com](mailto:ub2.industrie@mahle.com)